

**GCE A LEVEL – NEW**

1300U40-1

**WEDNESDAY, 12 JUNE 2019 – MORNING****MATHEMATICS – A2 unit 4  
APPLIED MATHEMATICS B**

1 hour 45 minutes

**ADDITIONAL MATERIALS**

In addition to this examination paper, you will need:

- a WJEC pink 16-page answer booklet;
- a Formula Booklet;
- a calculator;
- statistical tables (RND/WJEC Publications).

**INSTRUCTIONS TO CANDIDATES**

Use black ink or black ball-point pen. Do not use pencil or gel pen. Do not use correction fluid.

Answer **all** questions.

Write your answers in the separate answer booklet provided, following the instructions on the front of the answer booklet.

Use both sides of the paper. Please only write within the white areas of the booklet.

Write the question number in the two boxes in the left hand margin at the start of each answer, e.g. 

0	1
---	---

. Write the sub parts, e.g. **a**, **b** and **c**, within the white areas of the booklet.

Leave at least two line spaces between each answer.

Take  $g$  as  $9.8 \text{ ms}^{-2}$ .

Sufficient working must be shown to demonstrate the **mathematical** method employed.

Answers without working may not gain full credit.

Unless the degree of accuracy is stated in the question, answers should be rounded appropriately.

**INFORMATION FOR CANDIDATES**

The maximum mark for this paper is 80.

The number of marks is given in brackets at the end of each question or part-question.

You are reminded of the necessity for good English and orderly presentation in your answers.

**Reminder:** Sufficient working must be shown to demonstrate the **mathematical** method employed.

### Section A: Statistics

0	1
---	---

 Val buys electrical components from one of 3 suppliers  $A$ ,  $B$ ,  $C$ , in the ratio 2 : 1 : 7. The probability that the component is faulty is 0.33 for  $A$ , 0.45 for  $B$  and 0.05 for  $C$ . Val selects a component at random.

- a) Find the probability that the component works. [3]
- b) Given that the component works, find the probability that Val bought the component from supplier  $B$ . [2]

0	2
---	---

 Four children are playing a game in order to win a calculator. They take turns, starting with Alex, followed by Ben, then Caroline, then Danielle, rolling a fair six-sided dice until someone obtains a 6. This player then wins a calculator.

- a) Find the probability that
- i) Danielle wins the calculator on her first turn, [1]
  - ii) Ben wins the calculator on his first or second turn, [3]
  - iii) Caroline rolls the dice exactly twice. [3]
- b) Show that the probability that Alex wins the calculator is  $\frac{216}{671}$ . [3]

0 3

At a fairground, Kirsty throws  $n$  balls in order to try to knock coconuts off their stands. Any coconuts she knocks off are replaced before she throws again. Kirsty counts the number of coconuts she successfully knocks off their stands. On average, she knocks off a coconut with 20% of her throws.

- a) What assumptions are needed in order to model this situation with a binomial distribution? Explain whether these assumptions are reasonable. [2]

Kirsty uses a spreadsheet to produce the following diagrams, showing the probability distributions of the number of coconuts knocked off their stands for different values of  $n$ .

**Distribution for  $n = 6$**

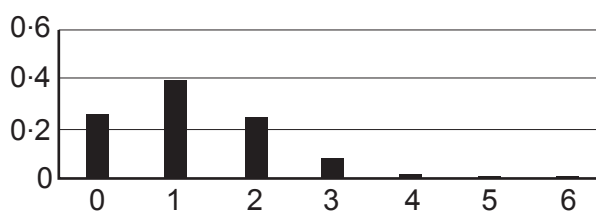

**Distribution for  $n = 13$**

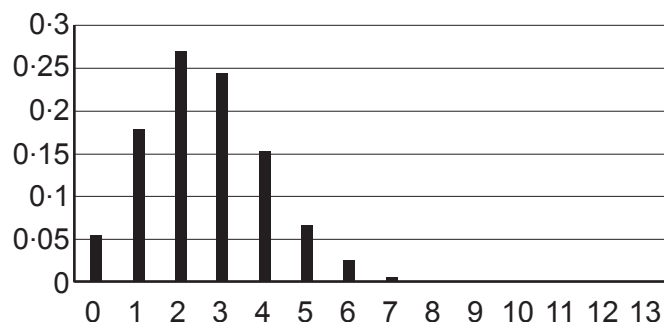

**Distribution for  $n = 55$**

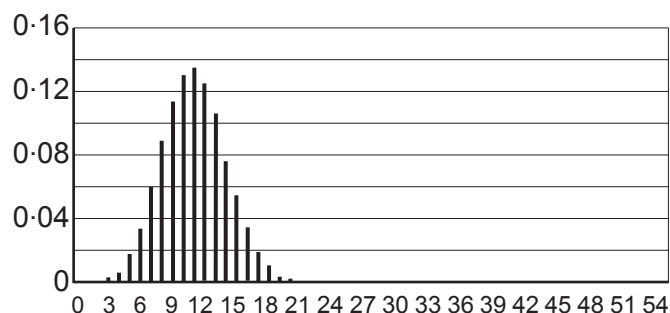

- b) Describe two ways in which the distribution changes as  $n$  increases. [2]

**TURN OVER**

0	4
---	---

 A company produces kettlebells whose weights are normally distributed with mean 16 kg and standard deviation 0.08 kg.

- a) Find the probability that the weight of a randomly selected kettlebell is greater than 16.05 kg. [2]

The company trials a new production method. It needs to check that the mean is still 16 kg. It assumes that the standard deviation is unchanged. The company takes a random sample of 25 kettlebells and it decides to reject the new production method if the sample mean does not round to 16 kg to the nearest 100 g.

- b) Find the probability that the new production method will be rejected if, in fact, the mean is still 16 kg. [4]

The company decides instead to use a 5% significance test. A random sample of 25 kettlebells is selected and the mean is found to be 16.02 kg.

- c) Carry out the test to determine whether or not the new production method will be rejected. [6]

0 5

A bowling alley manager in the UK is concerned about falling revenues. He collects data from the United States, hoping to use what he finds to revive his business in the UK.

He finds data which seem to show correlation between margarine consumption and bowling alley revenue. He attempts to carry out some statistical analysis in order to present his findings to the board of directors. He produces the scatter diagram shown below.

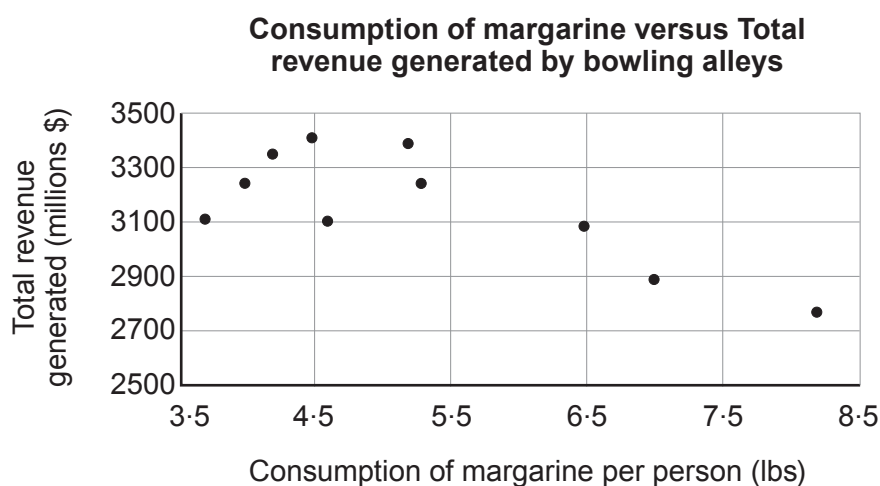

The product moment correlation coefficient for these data is  $-0.7617$ . He carries out a one-tailed test at the 1% level of significance and concludes that higher margarine consumption is associated with lower revenue generated by bowling alleys.

- a) Show all the working for this test. [5]

The manager also conducts a significance test for bowling alley revenue and fish consumption per person. He produces the computer output, shown below, for the analysis of bowling alley revenue versus fish consumption per person.

```
# Pearson's product-moment correlation
# data: revenue and fish
# t = 3.8303, df = 8, p-value = 0.005215
# alternative hypothesis: true correlation is not equal to 0
# sample estimates:
# correlation
# 0.8024423
```

- b) Comment on the correlation between bowling alley revenue and fish consumption per person and what the board of directors should do in light of the manager's findings in part (a) and part (b). [3]
- c) Give one possible reason why the board of directors might not be happy with the manager's analysis. [1]

## TURN OVER

### Section B: Differential Equations and Mechanics

- 0 6** A particle  $P$  of mass  $0.5$  kg moves on a horizontal plane such that its velocity vector  $\mathbf{v}$   $\text{ms}^{-1}$  at time  $t$  seconds is given by

$$\mathbf{v} = 12\cos(3t)\mathbf{i} - 5\sin(2t)\mathbf{j}.$$

- a) Find an expression for the force acting on  $P$  at time  $t$  s. [3]
- b) Given that when  $t = 0$ ,  $P$  has position vector  $(4\mathbf{i} + 7\mathbf{j})$  m relative to the origin  $O$ , find an expression for the position vector of  $P$  at time  $t$  s. [4]
- c) Hence determine the distance of  $P$  from  $O$  at time  $t = \frac{\pi}{2}$ . [2]

- 0 7** Three coplanar horizontal forces of magnitude  $21$  N,  $11$  N and  $8$  N act on a particle  $P$  in the directions shown in the diagram.

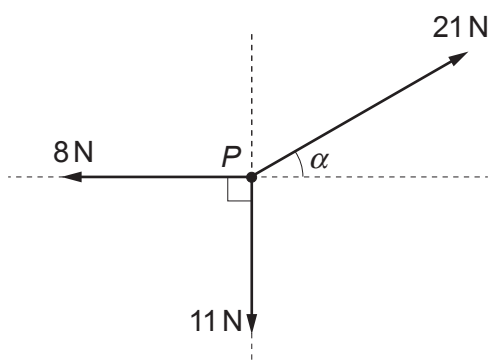

- a) Given that  $\tan \alpha = \frac{3}{4}$ , calculate the magnitude of the resultant force. [5]
- b) Explain why the forces cannot be in equilibrium whatever the value of  $\alpha$ . [1]

- 0 8** A box of mass  $2$  kg is projected along a horizontal surface with an initial velocity of  $5$   $\text{ms}^{-1}$ . The box experiences a variable resistive force of  $0.4v^2$  N, where  $v$   $\text{ms}^{-1}$  is the velocity of the box at time  $t$  seconds.

- a) Show that  $v$  satisfies the equation

$$5\frac{dv}{dt} + v^2 = 0. \quad [2]$$

- b) Find an expression for  $v$  in terms of  $t$ . [4]
- c) Briefly explain why this model is not particularly realistic. [1]

- 0 9** The diagram below shows a spotlight system that consists of a symmetrical track XY that is suspended horizontally from the ceiling by means of two vertical wires.

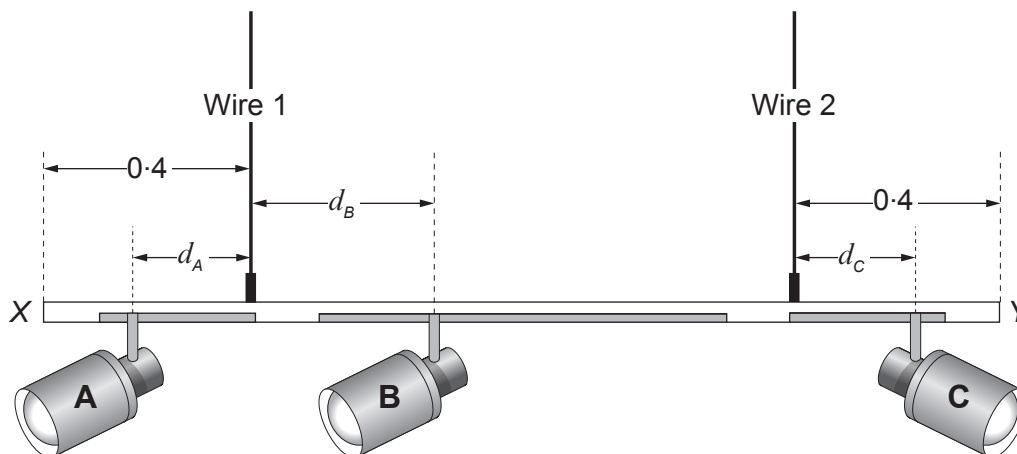

Each of the three spotlights  $A$ ,  $B$ ,  $C$  may be moved horizontally along its corresponding shaded section of the track. The system remains in equilibrium.

The track may be modelled as a **light** uniform rod of length  $1.8$  m and the wires are fixed at a distance of  $0.4$  m from each end. Each of the spotlights may be modelled as a particle of mass  $m$  kg, positioned at the points where they are in contact with the track.

The distances of the spotlights relative to the wires are given in the diagram and are such that

$$0 \leq d_A \leq 0.3, \quad 0.1 \leq d_B \leq 0.9, \quad 0 \leq d_C \leq 0.3.$$

- a) Given that  $T_1$  and  $T_2$  represent the tension in wires 1 and 2 respectively, show that

$$T_1 = mg(2 + d_A - d_B - d_C),$$

and find a similar expression for  $T_2$ . [6]

- b) i) Find the maximum possible value of  $T_1$ .
- ii) **Without carrying out any further calculations**, write down the maximum possible value of  $T_2$ . Give a reason for your answer. [3]

**TURN OVER**

- 1 0** A tennis ball is projected with velocity vector  $(30\mathbf{i} - 1.4\mathbf{j}) \text{ ms}^{-1}$  from a point  $P$  which is at a height of 2.4 m vertically above a horizontal tennis court. The ball then passes over a net of height 0.9 m, before hitting the ground after  $\frac{4}{7}$  s.

The unit vectors  $\mathbf{i}$  and  $\mathbf{j}$  are horizontal and vertical respectively. The origin  $O$  lies on the ground directly below the point  $P$ . The base of the net is  $x$  m from  $O$ .

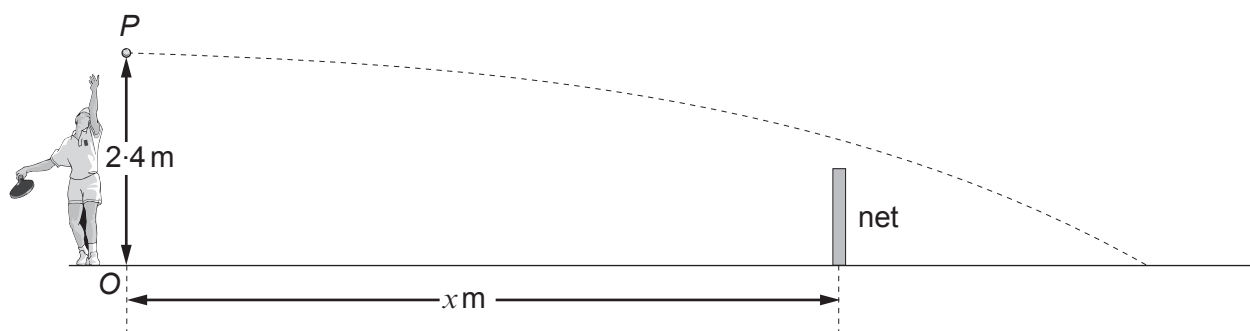

- a) Find the speed of the ball when it first hits the ground, giving your answer correct to one decimal place. [3]
- b) After  $\frac{2}{5}$  s, the ball is directly above the net.
- Find the position vector of the ball after  $\frac{2}{5}$  s.
  - Hence determine the value of  $x$  and show that the ball clears the net by approximately 16 cm. [4]
- c) In fact, the ball clears the net by only 4 cm.
- Explain why the observed value is different from the value calculated in (b)(ii).
  - Suggest a possible improvement to this model. [2]

**END OF PAPER**